

Edvo-Kit #

109

Edvo-Kit #109

DNA Fingerprinting by Restriction Enzyme Patterns

Experiment Objective:

The objective of this experiment is to develop a basic understanding of DNA fingerprinting. Variations in restriction enzyme cleavage patterns obtained from different DNA molecules will be analyzed and the possible perpetrator of a crime will be identified using the logic of DNA fingerprinting.

See page 3 for storage instructions.

Version 109.210628

EDVOTEK®

Table of Contents

	Page
Experiment Components	3
Experiment Requirements	3
Background Information	4
Experiment Procedures	
Experiment Overview	8
Module I: Agarose Gel Electrophoresis	10
Module II: Staining Agarose Gels Using FlashBlue™	12
Study Questions	13
Instructor's Guidelines	14
Pre-Lab Preparations	15
Experiment Results and Analysis	17
Study Questions and Answers	18
Appendices	19
A EDVOTEK® Troubleshooting Guide	20
B Bulk Preparation of Electrophoresis Buffer and Agarose Gels	21
C Using SYBR® Safe Stain (OPTIONAL)	22

Safety Data Sheets can be found on our website: www.edvotek.com/safety-data-sheets

Technical Support

1.800.EDVOTEK

Mon. - Fri. 8 AM to 5:30 PM EST



Please Have the Following Info:

- Product Number & Description
- Lot Number on Box
- Order/Purchase Order #

1.800.EDVOTEK • info@edvotek.com • www.edvotek.com

www.edvotek.com

- Online Catalog
- Order Products
- Experiment Protocols
- Tech Support
- Resources!



EDVOTEK and The Biotechnology Education Company are registered trademarks of EDVOTEK, Inc. Ready-to-Load, QuickStrip, FlashBlue, and UltraSpec-Agarose are trademarks of EDVOTEK, Inc. SYBR is a registered trademark of Thermo Fisher Scientific.



1.800.EDVOTEK • Fax 202.370.1501 • info@edvotek.com • www.edvotek.com

Duplication of any part of this document is permitted for non-profit educational purposes only. Copyright © 1989-2021 EDVOTEK, Inc., all rights reserved. Version 109.210628

Experiment Components

READY-TO-LOAD™ SAMPLES FOR ELECTROPHORESIS

Components (in QuickStrip™ format)

Store QuickStrip™ samples in the refrigerator upon receipt.

	Check (✓)
A DNA from crime scene cut with Enzyme 1	<input type="checkbox"/>
B DNA from crime scene cut with Enzyme 2	<input type="checkbox"/>
C DNA from Suspect 1 cut with Enzyme 1	<input type="checkbox"/>
D DNA from Suspect 1 cut with Enzyme 2	<input type="checkbox"/>
E DNA from Suspect 2 cut with Enzyme 1	<input type="checkbox"/>
F DNA from Suspect 2 cut with Enzyme 2	<input type="checkbox"/>

Experiment #109 is designed for 8 groups.

Store QuickStrip™ samples in the refrigerator immediately upon receipt. All other components can be stored at room temperature.

REAGENTS & SUPPLIES

Store the following at room temperature.

• UltraSpec-Agarose™	<input type="checkbox"/>
• Electrophoresis Buffer (50x)	<input type="checkbox"/>
• Practice Gel Loading Solution	<input type="checkbox"/>
• FlashBlue™ DNA Stain	<input type="checkbox"/>

Requirements

- Horizontal gel electrophoresis apparatus
- D.C. power supply
- Automatic micropipettes with tips
- Balance
- Microwave, hot plate or burner
- Pipet pump
- 250 mL flasks or beakers
- Hot gloves
- Safety goggles and disposable laboratory gloves
- Small plastic trays or large weigh boats (for gel destaining)
- DNA visualization system (white light)
- Distilled or deionized water

All experiment components are intended for educational research only. They are not to be used for diagnostic or drug purposes, nor administered to or consumed by humans or animals.

Background Information

DNA typing (also called DNA profile analysis or DNA fingerprinting) is the process whereby the genomic DNA of an organism is analyzed by examining several specific, variable DNA sequences located throughout the genome. In humans, DNA fingerprinting is now used routinely for identification purposes.

Human DNA fingerprinting was pioneered by Dr. Alex Jeffreys at the University of Leicester in 1984 which led to the apprehension of a murderer in the first DNA fingerprinting conviction in September 1987 in the UK. Two months later, the first U.S. conviction based on DNA fingerprinting occurred in Orlando, Florida. Since then, the use of DNA fingerprinting has led to thousands of criminal convictions, as well as dozens of exonerations.

In contrast to earlier methodologies, such as blood typing which can only exclude a suspect, DNA fingerprinting can provide positive identification with great accuracy. In addition to criminal identification cases, DNA fingerprinting is now used routinely in paternity determinations and for the identification of genetic disease "markers". It is also used for the identification of human remains, such as in war casualties, and was used extensively to identify victims of the September 11, 2001 terrorist attacks on the World Trade Center, the Pentagon, and passengers in the plane which crashed in a field near Shanksville, Pennsylvania.

Human cells contain two types of DNA. The first type is cellular chromosomal DNA, which is packaged in 23 sets of chromosomes in the nucleus of the cell. This DNA, obtained from both parents, reflects the combined parental genetic inheritance of an individual. DNA fingerprinting utilizing cellular DNA involves analysis of the sequence of two alleles for a particular gene.

The second type of DNA is different from cellular DNA and is present only in the mitochondria, which are the energy-producing organelles of the cell. Mitochondrial DNA is inherited maternally by both males and females and is extremely useful in the analysis of specific cases where fraternal linkages are important to determine. For example, a brother, sister, half brother or half sister who share the same mother would inherit the same mitochondrial DNA. Identification is determined by sequencing certain regions within mitochondrial DNA, which is a single circular chromosome composed of 16,569 base pairs.

DNA fingerprinting developed by Dr. Jeffreys utilizes cellular chromosomal DNA submitted to restriction enzyme digestion and Southern blot analysis. When human DNA is digested by a restriction enzyme, a very large number of DNA fragments are generated. When separated by agarose gel electrophoresis, the numerous DNA fragments appear as a "smear" on the gel. Labeled probes are used to detect Restriction Fragment Length Polymorphic (RFLP) regions within DNA, which will be described in greater detail. DNA RFLP analysis is statistically very accurate but requires relatively large amounts of DNA and takes several days to perform.

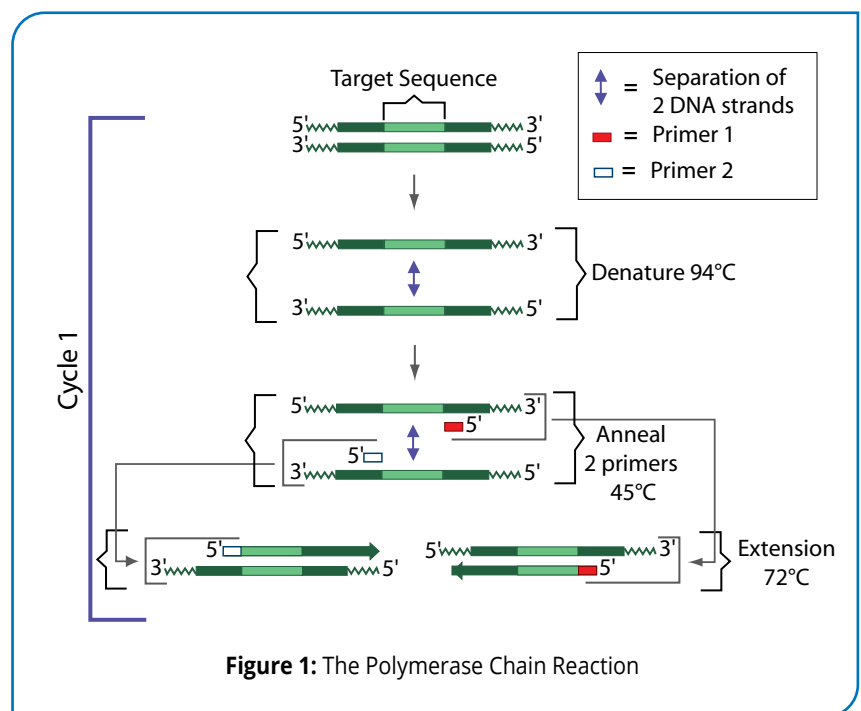

In recent years, the use of the RFLP method has been overtaken by the Polymerase Chain Reaction (PCR) method because of two important advantages. The first is the sensitivity of PCR, which allows for DNA fingerprinting identification using much smaller amounts of DNA. This is because PCR is able to amplify DNA to facilitate analysis. The second advantage is the speed of PCR analysis, which allows critical questions to be answered more quickly compared to Southern Blot analysis. One PCR cycle has three steps, resulting in a doubling of the amount of DNA (see Figure 1). The Polymerase Chain Reaction (PCR) method amplifies target sequences of DNA, which are referred to as AMRFLPs. PCR made it possible for very small amounts of DNA found at crime scenes to be amplified for DNA fingerprinting analysis. A specific set of two primers is used to prime DNA polymerase to synthesize many copies of the targeted areas of DNA.

Many important concepts of molecular biology can be conveyed in the context of DNA Fingerprinting methods. In this experiment, emphasis is placed on concepts related to RFLP analysis. The experiment activities will focus on the identification of DNA by analyzing restriction fragmentation patterns separated by agarose gel electrophoresis.

USE OF RESTRICTION ENZYMES IN DNA FINGERPRINTING

DNA fingerprinting involves the electrophoretic analysis of DNA fragment sizes generated by restriction enzymes. Restriction enzymes are endonucleases which catalyze the cleavage of phosphodiester bonds within both DNA strands. The sites of cleavage occur in or near very specific palindromic sequences of bases called recognition sites, which are generally 4 to 8 base pairs in length.

The two most commonly used restriction enzymes for DNA profile analysis are *Hae* III and *Hinf* I, which are 4-base and 5-base cutting enzymes. The examples in the Figure 2 show recognition sites for various restriction enzymes.

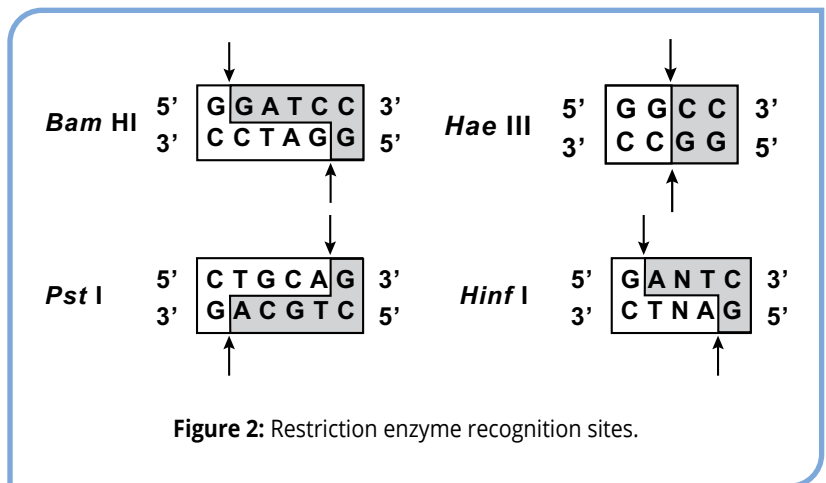

The size of the DNA fragments generated depends on the distance between the recognition sites. In general, the longer the DNA molecule, the greater the probability that a given recognition site will occur. Human DNA is very large and contains approximately three billion base pairs. A restriction enzyme having a 6-base pair recognition site, such as *Eco* RI, would be expected to cut human DNA into approximately 750,000 different fragments.

DNA is highly polymorphic - that is, no two individuals have exactly the same pattern of restriction enzyme recognition sites in their DNAs. A large number of alleles exist in the population. Alleles, which are alternate forms of a gene, result in alternative expressions of genetic traits which can be dominant or recessive.

Chromosomes occur in matching pairs, one of maternal and the other of paternal origin. The two copies of a gene (alleles) at a given chromosomal locus represent a composite of the parental genes constituting an individual's unique genotype. It follows that alleles have differences in their base sequences which consequently creates differences in the distribution and frequencies of restriction enzyme recognition sites. Other differences in base sequences between individuals can occur because of mutations and deletions. Such changes can also create or eliminate a recognition site.

Polymorphic DNA refers to chromosomal regions that vary widely from individual to individual. By examining several of these regions within the genomic DNA obtained from an individual, one may obtain a "DNA fingerprint" for that individual. The most commonly used polymorphisms are those that vary in length; these are known as Fragment Length Polymorphisms (FLPs). The main reason for the occurrence of RFLPs is because of variations in length of a given segment of genomic DNA between two restriction enzyme recognition sites among individuals of the same species.

Likewise, RFLP can occur in "intergenic" or noncoding regions of DNA and is known as Variable Number of Tandem Repeats (VNTRs). In this case, segments of DNA that contain sequences from 2 to 40 bases in length repeat in tandem manner many times. The number of segments or "core unit" repeats varies among individuals of the same species while the restriction enzyme cut sites are not altered. VNTR loci are very polymorphic. There are potentially hundreds of alleles at a single locus and therefore they are very useful in DNA fingerprinting. Ten to fifteen percent of mammalian DNA consists of sets of repeated, short sequences of bases that are tandemly arranged in arrays. The length of these arrays (the amount of repeated sets) varies between individuals at different chromosomal loci.

TGTTTA | TGTTTA | TGTTTA.....variable number

When these sequences in DNA are flanked by recognition sites, the length of the repeat will determine the size of the restriction enzyme fragment generated. There are several types of these short, repetitive sequences and they have been characterized.

DNA FINGERPRINTING USING SOUTHERN BLOTS

Agarose gel electrophoresis is a procedure used to analyze DNA fragments generated by restriction enzymes. The gel consists of microscopic pores that act as a molecular sieve. Samples of DNA are loaded into wells made in the gel during casting. Since DNA has a negative charge at neutral pH, it migrates through the gel towards the positive electrode during electrophoresis. DNA fragments are separated by the gel according to their size. The smaller the fragment the faster it migrates. After electrophoresis, the DNA can be visualized by staining the gel with dyes. Restriction enzyme cleavage of relatively small DNA molecules, such as plasmids and viral DNAs, usually results in discrete banding patterns of the DNA fragments after electrophoresis. However, cleavage of large and complex DNA, such as human chromosomal DNA, generates so many differently sized fragments that the resolving capacity of the gel is exceeded. Consequently, the cleaved DNA is visualized as a smear after staining and has no obvious banding patterns.

RFLP analysis of genomic DNA is facilitated by Southern Blot analysis. After electrophoresis, the DNA fragments in the gel are denatured by soaking in an alkali solution. This causes double-stranded DNA fragments to be converted into single-stranded form (no longer base-paired in a double helix). A replica of the electrophoretic pattern of DNA fragments in the gel is made by transferring (blotting) them to a sheet of nylon membrane. This is done by placing the membrane on the gel after electrophoresis and transferring the fragments to the membrane by capillary action or suction by vacuum. The DNA, which is not visible, becomes permanently adsorbed to the membrane, and can be manipulated easier than gels.

Analysis of the blotted DNA is done by hybridization with a labeled DNA probe. In forensic RFLP analysis, the probe is a DNA fragment that contains base sequences which are complementary to the variable arrays of tandemly repeated sequences found in the human chromosomes. Probes can be labeled with isotopic or non-isotopic reporter molecules, such as

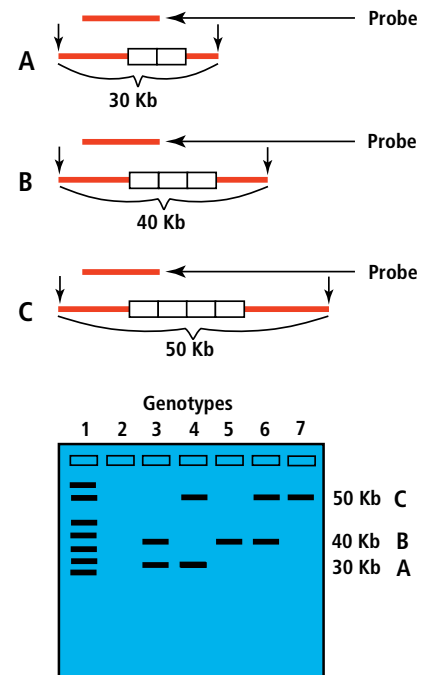

Probe overlaps both the variable region, as well as adjacent part of the genome. Arrows show restriction enzyme sites with probe for Southern Blot analysis. PCR can also be used to detect variable nucleotide regions.

Lane 1	DNA Marker
Lane 2	Homozygous Copies
Lane 3	Heterozygous VNTR
Lane 4	Heterozygous VNTR
Lane 5	Homozygous Copies
Lane 6	Heterozygous VNTR
Lane 7	Homozygous Copies

(Lanes 3, 4, and 6 represent different combinations of the three VNTRs.)

Figure 3: RFLP analysis demonstrating Variable Numbers of Nucleotide Tandem Repeats (VNTR).

fluorescent dyes used for detection. A solution containing the single-stranded probe is incubated with the membrane containing the blotted, single-stranded (denatured) DNA fragments. Under the proper conditions, the probe will only base pair (hybridize) to those fragments containing the complementary repeated sequences. The membrane is then washed to remove excess probe. If the probe is isotopically labeled to the membrane, it is then placed on an x-ray film for several hours. This process is known as autoradiography. Only DNA fragments that have hybridized to the probe will reveal their positions on the film because the localized areas of radioactivity cause exposure. The hybridized fragments appear as discrete bands (fingerprint) on the film and are in the same relative positions as they were in the agarose gel after electrophoresis. Only specific DNA fragments, of the hundreds of thousands of fragments present, will hybridize with the probe because of the selective nature of the hybridization (base pairing) process.

In forensic cases, DNA samples can be extracted and purified from small specimens of skin, blood, semen, or hair roots collected at the crime scene. DNA that is suitable for analysis can also be obtained from dried stains of semen and blood. The RFLP analyses performed on these samples is then compared to samples obtained from the suspect. If the RFLP patterns match, it is then beyond reasonable doubt that the suspect was at the crime scene. In practice, several different probes containing different types of repetitious sequences are used in the hybridizations in order to satisfy certain statistical criteria for absolute, positive identification. To assure positive identification in criminal cases, 13 different loci are compared between a suspect and evidence DNA obtained from the crime scene.

In this experiment, DNAs are pre-digested by restriction enzymes and the fragmentation patterns serve as the individual fingerprint. The DNA fragmentation patterns can be analyzed directly in the stained agarose gel, which eliminates the need for a Southern blot. In this hypothetical case, DNA obtained from two suspects are cleaved with two restriction enzymes in separate reactions. The objective is to analyze and match the DNA fragmentation patterns after agarose gel electrophoresis and determine if Suspect 1 or Suspect 2 was at the crime scene.

THIS EXPERIMENT DOES NOT CONTAIN HUMAN DNA.

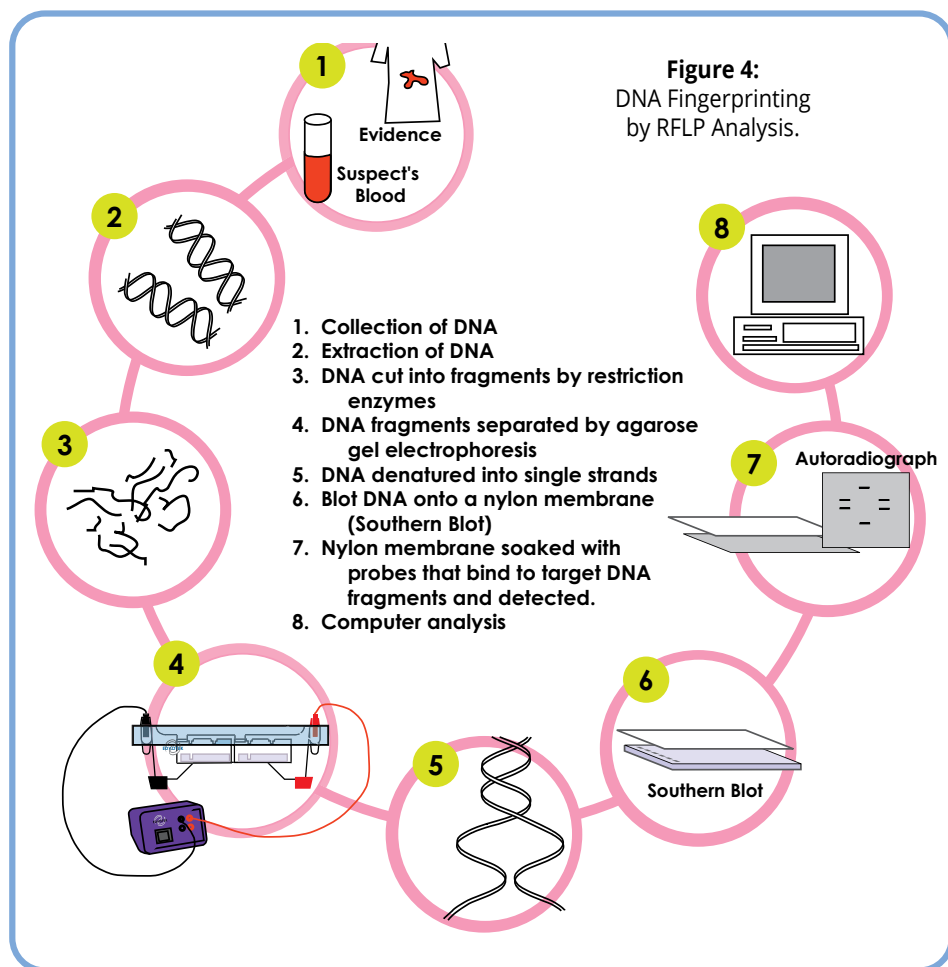

Experiment Overview

EXPERIMENT OBJECTIVE

The objective of this experiment is to develop a basic understanding of DNA fingerprinting. Variations in restriction enzyme cleavage patterns obtained from different DNA molecules will be analyzed and the possible perpetrator of a crime will be identified using the logic of DNA fingerprinting.

LABORATORY SAFETY

1. Gloves and goggles should be worn routinely as good laboratory practice.
2. Exercise extreme caution when working with equipment that is used in conjunction with the heating and/or melting of reagents.
3. DO NOT MOUTH PIPET REAGENTS - USE PIPET PUMPS.
4. Exercise caution when using any electrical equipment in the laboratory.
5. Always wash hands thoroughly with soap and water after handling reagents or biological materials in the laboratory.



LABORATORY NOTEBOOKS

Scientists document everything that happens during an experiment, including experimental conditions, thoughts and observations while conducting the experiment, and, of course, any data collected. Today, you'll be documenting your experiment in a laboratory notebook or on a separate worksheet.

Before starting the Experiment:

- Carefully read the introduction and the protocol. Use this information to form a hypothesis for this experiment.
- Predict the results of your experiment.

During the Experiment:

- Record your observations.

After the Experiment:

- Interpret the results – does your data support or contradict your hypothesis?
- If you repeated this experiment, what would you change? Revise your hypothesis to reflect this change.

Experiment Overview

MODULE I: Agarose Gel Electrophoresis

Time required: See Table C

Quick Reference for EDVO-Kit #109			
Size of gel casting tray	Groups per gel	Placement of comb	Wells required per group
7 x 7 cm	1 group	1st set of notches	6
10 x 7 cm	1 group	1st set of notches	6
14 x 7 cm	2 groups	1st and 3rd sets of notches	6

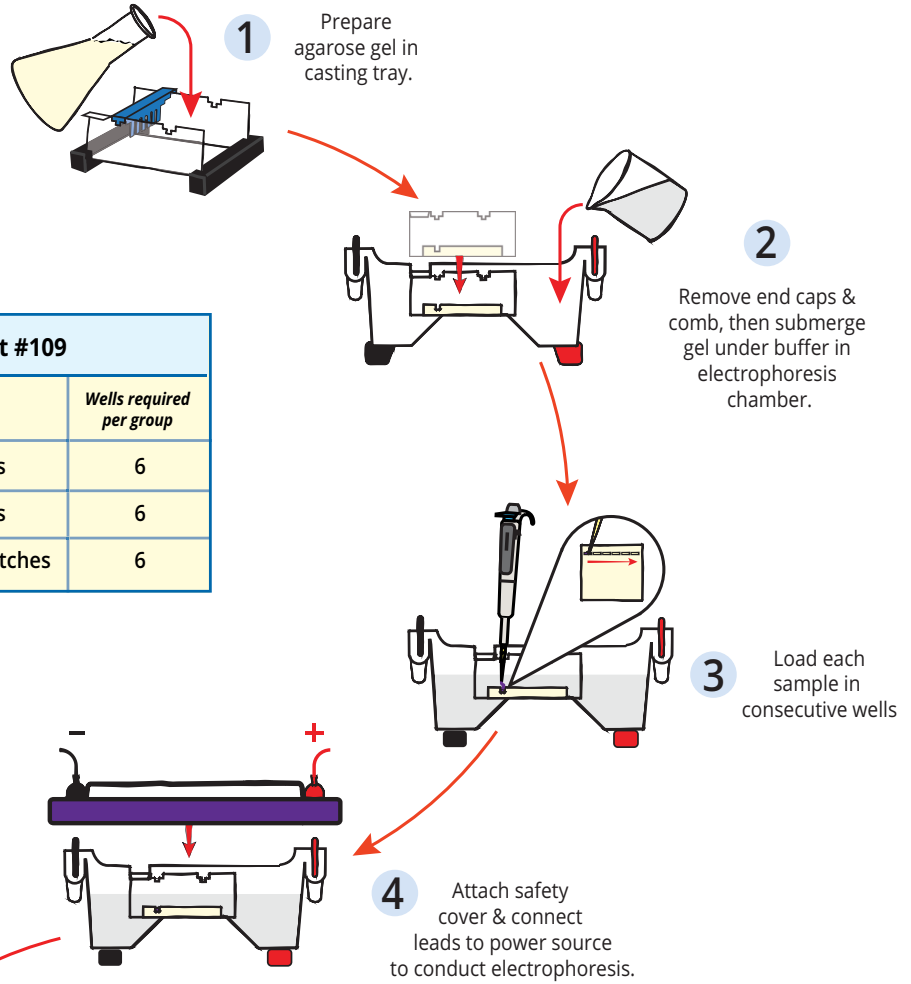

MODULE II: Staining Agarose Gels Using FlashBlue™

Time required: 30 min.

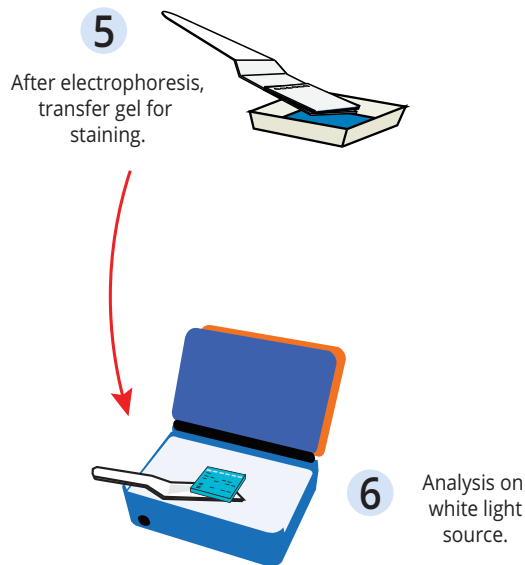

Related EDVOTEK® Instructional Videos

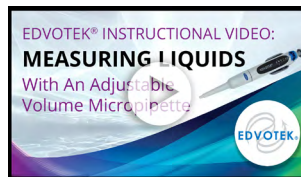

www.youtube.com/edvotekinc

Module I: Agarose Gel Electrophoresis

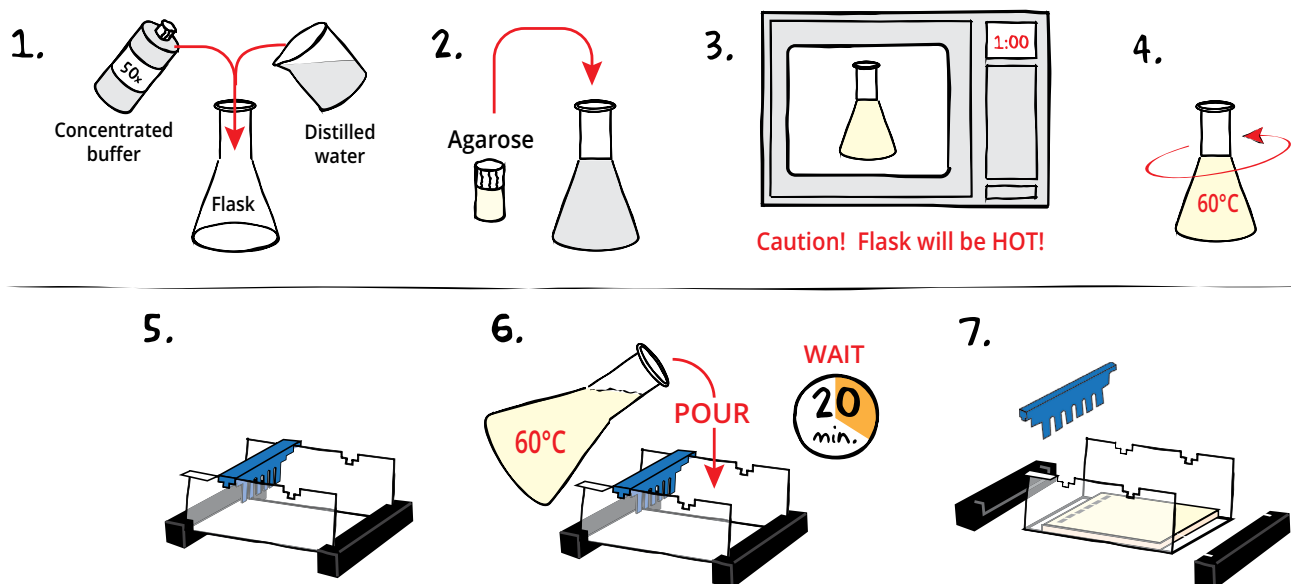

CASTING THE AGAROSE GEL

- DILUTE** concentrated 50X Electrophoresis buffer with distilled water (refer to Table A for correct volumes depending on the size of your gel casting tray).
- MIX** agarose powder with buffer solution in a 250 mL flask (refer to Table A).
- DISSOLVE** agarose powder by boiling the solution. **MICROWAVE** the solution on high for 1 minute. Carefully **REMOVE** the flask from the microwave and **MIX** by swirling the flask. Continue to **HEAT** the solution in 15-second bursts until the agarose is completely dissolved (the solution should be clear like water).
- COOL** agarose to 60 °C with careful swirling to promote even dissipation of heat.
- While agarose is cooling, **SEAL** the ends of the gel-casting tray with the rubber end caps. **PLACE** the well template (comb) in the appropriate notch.
- POUR** the cooled agarose solution into the prepared gel-casting tray. The gel should thoroughly solidify within 20 minutes. The gel will stiffen and become less transparent as it solidifies.
- REMOVE** end caps and comb. Take particular care when removing the comb to prevent damage to the wells.



Wear gloves and safety goggles

REMINDER:

This experiment requires 0.8% agarose gels cast with 6 wells.

Size of Gel Casting tray	Concentrated Buffer (50x)	+ Distilled Water	+ Amt of Agarose	= TOTAL Volume
7 x 7 cm	0.6 mL	29.4 mL	0.24 g	30 mL
10 x 7 cm*	0.9 mL	44.1 mL	0.36 g	45 mL
14 x 7 cm	1.2 mL	58.8 mL	0.48 g	60 mL

*Recommended gel volume for the EDGE™ Integrated Electrophoresis System. (Cat. #500).

Module I: Agarose Gel Electrophoresis

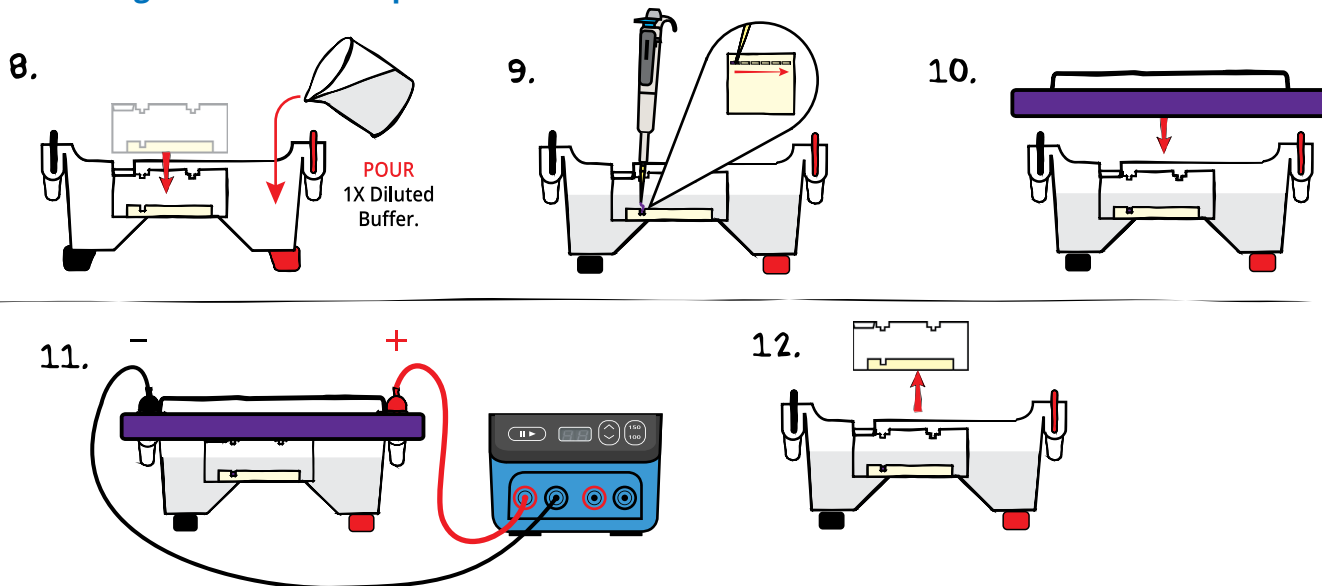

RUNNING THE GEL

8. **PLACE** the gel (still on the tray*) into the electrophoresis chamber. **COVER** the gel with 1X Electrophoresis Buffer (See Table B for recommended volumes). The gel should be completely submerged.
9. **PUNCTURE** the foil overlay of the QuickStrip™ with a pipet tip. **LOAD** the entire sample (35 µL) into the well in the order indicated by Table 1, at right.
10. **PLACE** safety cover on the unit. **CHECK** that the gel is properly oriented. Remember, the DNA samples will migrate toward the positive (red) electrode.
11. **CONNECT** leads to the power source and **PERFORM** electrophoresis (See Table C for time and voltage guidelines). Allow the tracking dye to migrate at least 3 cm from the wells.
12. After electrophoresis is complete, **REMOVE** the gel and casting tray from the electrophoresis chamber.

REMINDER:
Before loading the samples, make sure the gel is properly oriented in the apparatus chamber.

TABLE 1: GEL LOADING

Lane 1	Tube	DNA from crime scene cut with Enzyme 1
2	Tube B	DNA from crime scene cut with Enzyme 2
3	Tube C	DNA from Suspect 1 cut with Enzyme 1
4	Tube D	DNA from Suspect 1 cut with Enzyme 2
5	Tube E	DNA from Suspect 2 cut with Enzyme 1
6	Tube F	DNA from Suspect 2 cut with Enzyme 2

PROCEED to Module II: Staining Agarose Gels Using FlashBlue™.

Table
B

1x Electrophoresis Buffer (Chamber Buffer)

EDVOTEK Model #	Total Volume Required	Dilution	
		50x Conc. Buffer	+ Distilled Water
EDGE™	150 mL	3 mL	147 mL
M12	400 mL	8 mL	392 mL
M36	1000 mL	20 mL	980 mL

Table
C

Time and Voltage Guidelines (0.8% Agarose Gel)

Volts	Electrophoresis Model	
	EDGE™	M12 & M36
	Min/Max (minutes)	Min/Max (minutes)
150	10/20	20/35
125	N/A	30/45
100	15/25	40/60

*Gels that have previously been removed from their trays should be "anchored" back to the tray with a few drops of molten agarose before placing into the electrophoresis chamber. This will prevent the gels from sliding around in the trays and the chambers.

Module II: Staining Agarose Gels Using FlashBlue™

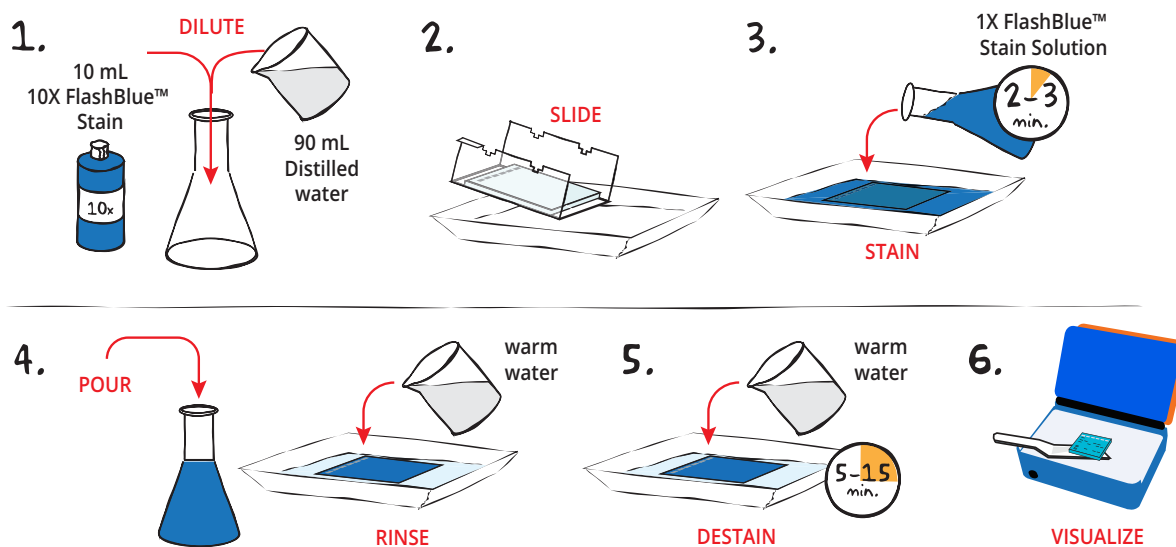

- DILUTE** 10 mL of 10X concentrated FlashBlue™ with 90 mL of distilled water in a flask. **MIX** well.
- REMOVE** the agarose gel and casting tray from the electrophoresis chamber. **SLIDE** the gel off the casting tray into a small, clean gel-staining tray.
- COVER** the gel with the 1X FlashBlue™ stain solution. **STAIN** the gel for 2-3 minutes. For best results, use an orbital shaker to gently agitate the gel while staining. **STAINING THE GEL FOR LONGER THAN 3 MINUTES WILL REQUIRE EXTRA DESTAINING TIME.**
- POUR** the 1X FlashBlue™ back into the flask (the stain can be reused). **COVER** the gel with warm water (40-45 °C). Gently **RINSE** the gel for 20-30 seconds. **POUR** off the water.
- COVER** the gel with clean, warm water (40-45 °C). **DESTAIN** for 5-15 minutes with gentle shaking (longer periods will yield better results). DNA bands will start to appear after 5 minutes of destaining. Changing the water frequently will accelerate destaining.
- Carefully **REMOVE** the gel from the destaining liquid. **VISUALIZE** results using a white light visualization system. DNA will appear as dark blue bands on a light blue background.



ALTERNATIVE FLASHBLUE™ STAINING PROTOCOL:

- DILUTE** 1 mL of 10X FlashBlue™ stain with 149 mL distilled water.
- COVER** the gel with diluted FlashBlue™ stain.
- SOAK** the gel in the staining liquid for at least three hours. For best results, stain gels overnight.
- Carefully **REMOVE** the gel from the staining liquid. **VISUALIZE** results using a white light visualization system. DNA will appear as dark blue bands on a light blue background.

Study Questions

1. Define FLP's and give their significance.
2. What is the most likely cause of Restriction Fragment Length Polymorphisms?
3. What are Variable Number of Tandem Repeats (VNTRs)?
4. Who are the only individuals possessing the same DNA fingerprints?
5. List the steps involved in DNA fingerprinting from extraction of DNA through the matching of a suspect to a crime scene sample.
6. What type of human cells can be utilized for this technique?

Instructor's Guide

ADVANCE PREPARATION:

PREPARATION FOR:	WHAT TO DO:	WHEN?	TIME REQUIRED:
Module I: Agarose Gel Electrophoresis	Prepare QuickStrips™.	Up to one day before performing the experiment.	45 min.
	Prepare diluted electrophoresis buffer.		
	Prepare molten agarose and pour gels.		
Module II: Staining Agarose Gels Using FlashBlue™	Prepare staining components.	The class period or overnight after the class period.	10 min.

Technical Support

1.800.EDVOTEK

Mon. - Fri. 8 AM to 5:30 PM EST



Please Have the Following Info:

- Product Number & Description
- Lot Number on Box
- Order/Purchase Order #

1.800.EDVOTEK • info@edvotek.com • www.edvotek.com

www.edvotek.com

- Online Catalog
- Order Products
- Experiment Protocols
- Tech Support
- Resources!



Pre-Lab Preparations: Module I

AGAROSE GEL ELECTROPHORESIS

This experiment requires 0.8% agarose gels. Enough reagents are provided to cast either eight 7 x 7 cm gels, eight 10 x 7 cm gels, or four 14 x 7 cm gels. You can choose whether to prepare the gels in advance or have students prepare their own. Allow approximately 30 minutes for this procedure.

Quick Reference for EDVO-Kit #109			
Size of gel casting tray	Groups per gel	Placement of comb	Wells required per group
7 x 7 cm	1 group	1st set of notches	6
10 x 7 cm	1 group	1st set of notches	6
14 x 7 cm	2 groups	1st and 3rd sets of notches	6

Individual Gel Preparation:

Each student group can be responsible for casting their own individual gel prior to conducting the experiment. See Module I in the Student's Experimental Procedure. Students will need 50x concentrated buffer, distilled water and agarose powder.

Batch Gel Preparation:

To save time, a larger quantity of agarose solution can be prepared for sharing by the class. Electrophoresis buffer can also be prepared in bulk. See Appendix B.

Preparing Gels in Advance:

Gels may be prepared ahead and stored for later use. Solidified gels can be stored under buffer in the refrigerator for up to 2 weeks.

Do not freeze gels at -20 °C as freezing will destroy the gels.

Gels that have been removed from their trays for storage should be "anchored" back to the tray with a few drops of molten agarose before being placed into the tray. This will prevent the gels from sliding around in the trays and the chambers.

SAMPLES FORMAT: PREPARING THE QUICKSTRIPS™

QuickStrip™ tubes consist of a microtiter block covered with a protective foil overlay. Each well contains pre-aliquoted sample.

Using sharp scissors, carefully divide the block of tubes into individual strips by cutting between the rows (see diagram at right). Take care not to damage the foil overlay while separating the samples.

Each lab group will receive one set of tubes. Before loading the gel, remind students to tap the tubes to collect the sample at the bottom of the tube. Puncture the foil overlay of the QuickStrip™ with a pipet tip to aspirate the sample. **Do not remove the foil as samples can spill.**

FOR MODULE I
Each group will need:

- 50x concentrated buffer
- Distilled Water
- UltraSpec-Agarose™
- QuickStrip™ Samples

NOTE:
This kit is compatible with **SYBR® Safe Stain** (Cat #608, not included). Instructions for preparing gels and visualizing results can be found in Appendix C.

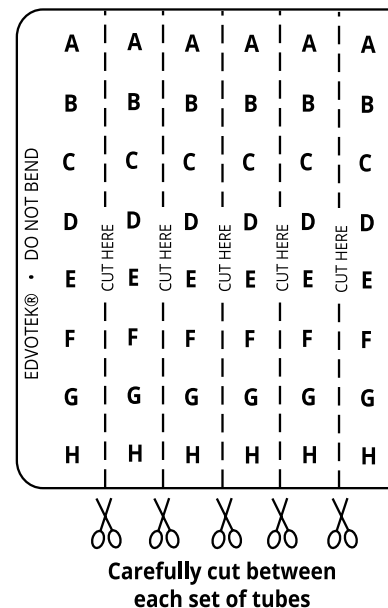

Pre-Lab Preparations: Module II

STAINING AGAROSE GELS USING FLASHBLUE™

FlashBlue™ stain is optimized to shorten the time required for both staining and destaining steps. Agarose gels can be stained with diluted FlashBlue™ for 5 minutes and destained for only 20 minutes. For the best results, leave the gel in liquid overnight. This will allow the stained gel to “equilibrate” in the destaining solution, resulting in dark blue DNA bands contrasting against a uniformly light blue background. A white light box ([Cat. #552](#)) is recommended for visualizing gels stained with FlashBlue™.

- Stained gels may be stored in destaining liquid for several weeks with refrigeration, although the bands may fade with time. If this happens, re-stain the gel.
- Destained gels can be discarded in solid waste disposal. Destaining solutions can be disposed of down the drain.

FOR MODULE II Each group will need:

- 10 mL 10X concentrated FlashBlue *OR*
100 mL 1x diluted FlashBlue
- Small plastic tray or weight boat
- Distilled or deionized water

PHOTODOCUMENTATION OF DNA (OPTIONAL)

Once gels are stained, you may wish to photograph your results. There are many different photodocumentation systems available, including digital systems that are interfaced directly with computers. Specific instructions will vary depending upon the type of photodocumentation system you are using.

NOTE:

Accurate pipetting is critical for maximizing successful experiment results. EDVOTEK Series 100 experiments are designed for students who have had previous experience with micropipetting techniques and agarose gel electrophoresis.

If students are unfamiliar with using micropipettes, we recommended performing [Cat. #S-44, Micropipetting Basics](#) or [Cat. #S-43, DNA DuraGel™](#) prior to conducting this experiment.

Experiment Results and Analysis

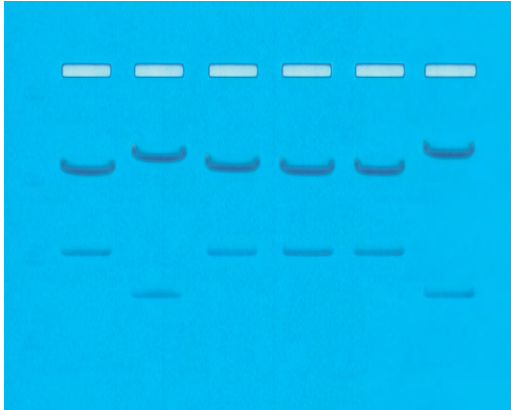

In the idealized schematic, the relative positions of DNA fragments are shown but are not depicted to scale.

Lane	Tube	Sample	Molecular Weights (in bp)
1	A	DNA from Crime Scene Cut with Enzyme 1	3000, 1282
2	B	DNA from Crime Scene Cut with Enzyme 2	3440, 842
3	C	DNA from Suspect 1 Cut with Enzyme 1	3000, 1282
4	D	DNA from Suspect 1 Cut with Enzyme 2	3000, 1282
5	E	DNA from Suspect 2 Cut with Enzyme 1	3000, 1282
6	F	DNA from Suspect 2 Cut with Enzyme 2	3440, 842

ANALYSIS

- Lanes 1 and 2 (set one) represent the crime scene DNA digested by two different restriction enzymes, which yield distinctly different DNA banding patterns.
- Lanes 3 and 4 (set two) represent DNA from Suspect 1. The suspect's DNA has been digested with the same two restriction enzymes as in Lanes 1 and 2.
- Lanes 5 and 6 (set three) represent DNA from Suspect 2. It also has been digested with the same two enzymes as the crime scene DNA (Lanes 1 and 2) and DNA from Suspect 1 (Lanes 3 and 4).
- The match between the crime scene DNA and Suspect 2 provides strong evidence that the suspect was present at the crime scene.

Discussion Question:

Could these DNA samples have been distinguished from one another if only Enzyme 1 had been used?

**Please refer to the kit
insert for the Answers to
Study Questions**

Appendices

- A EDVOTEK® Troubleshooting Guide
- B Bulk Preparation of Electrophoresis Buffer and Agarose Gels
- C Using SYBR® Safe Stain (OPTIONAL)

Safety Data Sheets can be found on our website: www.edvotek.com/safety-data-sheets

Technical Support

1.800.EDVOTEK

Mon. - Fri. 8 AM to 5:30 PM EST



Please Have the Following Info:

- Product Number & Description
- Lot Number on Box
- Order/Purchase Order #

1.800.EDVOTEK • info@edvotek.com • www.edvotek.com

www.edvotek.com

- Online Catalog
- Order Products
- Experiment Protocols
- Tech Support
- Resources!



Appendix A

EDVOTEK® Troubleshooting Guides

PROBLEM:	CAUSE:	ANSWER:
Bands are not visible on the gel.	The gel was not prepared properly.	Ensure that the electrophoresis buffer was correctly diluted.
	The gel was not stained properly.	Repeat staining protocol.
	Malfunctioning electrophoresis unit or power source.	Contact the manufacturer of the electrophoresis unit or power source.
After staining the gel, the DNA bands are faint.	The gel was not stained for a sufficient period of time.	Repeat staining protocol.
	The background of gel is too dark after staining with FlashBlue™.	Destain the gel for 5-10 minutes in distilled water.
DNA bands were not resolved.	Tracking dye should migrate at least 3 cm from the wells to ensure adequate separation.	Be sure to run the gel at least 3 cm before staining and visualizing the DNA (approximately 15-20 minutes at 150 V).
DNA bands fade when gels are kept at 4 °C.	DNA stained with FlashBlue™ may fade with time.	Re-stain the gel with FlashBlue™.
There is no separation between DNA bands, even though the tracking dye ran the appropriate distance.	The wrong percent gel was used for electrophoretic separation.	Be sure to prepare the correct percent agarose gel. For reference, the Ready-to-Load™ DNA samples should be analyzed using a 0.8% agarose gel.
There's not enough sample in my QuickStrip™.	The QuickStrip™ has dried out.	Add 40 µL water, gently pipet up and down to mix before loading.

Visit www.edvotek.com for additional troubleshooting suggestions.

Appendix B

Bulk Preparation of Electrophoresis Buffer and Agarose Gels

To save time, the electrophoresis buffer and agarose gel solution can be prepared in larger quantities for sharing by the class. Unused diluted buffer can be used at a later time and solidified agarose gel solution can be remelted.

Bulk Electrophoresis Buffer

Quantity (bulk) preparation for 3 liters of 1x electrophoresis buffer is outlined in Table D.

Table D Bulk Preparation of Electrophoresis Buffer			
50x Conc. Buffer	+	Distilled Water	Total Volume Required
60 mL		2,940 mL	3000 mL (3 L)

Batch Agarose Gels (0.8%)

For quantity (batch) preparation of 0.8% agarose gels, see Table E.

1. Use a 500 mL flask to prepare the diluted gel buffer.
2. Pour 3.0 grams of UltraSpec-Agarose™ into the prepared buffer. Swirl to disperse clumps.
3. With a marking pen, indicate the level of solution volume on the outside of the flask.
4. Heat the agarose solution as outlined previously for individual gel preparation. The heating time will require adjustment due to the larger total volume of gel buffer solution.
5. Cool the agarose solution to 60 °C with swirling to promote even dissipation of heat. If evaporation has occurred, add distilled water to bring the solution up to the original volume as marked on the flask in step 3.
6. Dispense the required volume of cooled agarose solution for casting each gel. Measure 30 mL for a 7 x 7 cm tray, 45 mL for a 10 x 7 cm tray, and 60 mL for a 14 x 7 cm tray. **For this experiment, 7 x 7 cm gels are recommended.**
7. Allow the gel to completely solidify. It will become firm and cool to the touch after approximately 20 minutes. Solidified gels can be stored under buffer in the refrigerator for up to 2 weeks. Do not freeze gels.

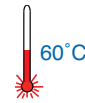

Table E Batch Prep of 0.8% UltraSpec-Agarose™					
Amt of Agarose	+	Concentrated Buffer (50X)	+	Distilled Water	Total Volume
3.0 g		7.5 mL		367.5 mL	375 mL

NOTE:

The UltraSpec-Agarose™ kit component is usually labeled with the amount it contains. Please read the label carefully. If the amount of agarose is not specified or if the bottle's plastic seal has been broken, weigh the agarose to ensure you are using the correct amount.

PROCEED to Loading and Running the Gel (page 11).

Appendix C

Using SYBR® Safe DNA Stain (OPTIONAL)

If desired, the DNA samples in this experiment can be visualized using [SYBR® Safe DNA stain \(Cat #608\)](#).

We recommend adding diluted SYBR® Safe stain to the liquid agarose gels while casting for easy, reproducible results. A blue light or UV transilluminator is needed for visualizing SYBR® gels. The TruBlu™ 2 ([Cat. #557](#)) is highly recommended.

PREPARING SYBR® SAFE STAIN

Instructors:

1. Prepare 1x Electrophoresis Buffer by combining 10 µL of 50X Concentrated Buffer with 490 µL of distilled water.
2. Add 20 µL of the SYBR® Safe to the tube of 1X buffer from Step 1 and mix by tapping the tube several times. The diluted SYBR® Safe Stain is now ready to be used during agarose gel preparation.

AGAROSE GEL PREPARATION

This experiment requires one 0.8% agarose gel for each student group. Instructors can choose whether to prepare the gels in advance (METHOD A) or have the students prepare their own (METHOD B). Allow approximately 30-40 minutes for this procedure.

Instructor Preparation (METHOD A):

For quantity (batch) preparation of agarose gels, see Table E.

1. Use a 500 mL flask to prepare the diluted gel buffer.
2. Pour 3.0 grams of UltraSpec-Agarose™ into the prepared buffer. Swirl to disperse clumps.
3. With a marking pen, indicate the level of solution volume on the outside of the flask.
4. Heat the agarose solution as outlined previously for individual gel preparation. The heating time will require adjustment due to the larger total volume of gel buffer solution.
5. Cool the agarose solution to 60 °C with swirling to promote even dissipation of heat. If evaporation has occurred, add distilled water to bring the solution up to the original volume as marked on the flask in step 3.
6. Add the entire tube of **diluted SYBR® Safe** stain to the cooled agarose and mix well.
7. Dispense the required volume of cooled agarose solution for casting each gel. Measure 30 mL for a 7 x 7 cm tray, 45 mL for a 10 x 7 cm tray, and 60 mL for a 14 x 7 cm tray. **For this experiment, 7 x 7 cm gels are recommended.**
8. Allow the gel to completely solidify. It will become firm and cool to the touch after approximately 20 minutes. Solidified gels can be stored in the refrigerator for up to 2 weeks. Place 1-2 mL of electrophoresis buffer in a sealable bag with the gels to prevent them from drying out. Excessive buffer will cause SYBR® Safe to diffuse out of the gels. Do not freeze gels.

PROCEED to Loading and Running the Gel (Steps 8-12 on page 11), followed by the VISUALIZATION procedures on page 24.

NO ADDITIONAL STAINING IS NECESSARY.

Table E					
Batch Prep of 0.8% UltraSpec-Agarose™					
Amt of Agarose	+	Concentrated Buffer (50X)	+	Distilled Water	Total Volume
3.0 g		7.5 mL		367.5 mL	375 mL



Appendix C

Using SYBR® Safe DNA Stain (OPTIONAL)

AGAROSE GEL PREPARATION, CONTINUED

Student Preparation (METHOD B):

For student preparation of agarose gels, see Table A.2.

1. **DILUTE** concentrated (50X) buffer with distilled water to create 1X buffer (see Table A.2).
2. **MIX** agarose powder with 1X buffer in a 250 mL flask (see Table A).
3. **DISSOLVE** agarose powder by boiling the solution. **MICROWAVE** the solution on high for 1 minute. Carefully **REMOVE** the flask from the microwave and **MIX** by swirling the flask. Continue to **HEAT** the solution in 15-second bursts until the agarose is completely dissolved (the solution should be clear like water).

Table A.2 Individual 0.8% UltraSpec-Agarose™ with SYBR® Stain					
Size of Gel Casting tray	Concentrated Buffer (50x)	Distilled Water	Amt of Agarose	TOTAL Volume	Diluted SYBR® (Step 6)
7 x 7 cm	0.6 mL	29.4 mL	0.24 g	30 mL	30 µL
10 x 7 cm*	0.9 mL	44.1 mL	0.36 g	45 mL	45 µL
14 x 7 cm	1.2 mL	58.8 mL	0.48 g	60 mL	60 µL

* Recommended gel volume for the EDGE™ Integrated Electrophoresis System.

4. **COOL** agarose to 60 °C with careful swirling to promote even dissipation of heat. 
5. While agarose is cooling, **SEAL** the ends of the gel-casting tray with the rubber end caps. **PLACE** the well template (comb) in the appropriate notch.
6. Before casting the gel, **ADD diluted SYBR® Safe** to the cooled agarose and swirl to mix (see Table A.2).
7. **POUR** the cooled agarose solution into the prepared gel-casting tray. The gel should thoroughly solidify within 20 minutes. The gel will stiffen and become less transparent as it solidifies.
8. **REMOVE** end caps and comb. Take particular care when removing the comb to prevent damage to the wells.

PROCEED to Loading and Running the Gel (Steps 8-12 on page 11), followed by the VISUALIZATION procedures on page 24. **NO ADDITIONAL STAINING IS NECESSARY.**

Appendix C

Using SYBR® Safe DNA Stain (OPTIONAL)

VISUALIZING THE SYBR® GEL

A blue light or UV transilluminator is needed for visualizing SYBR® gels. The TruBlu™ 2 ([Cat. #557](#)) is highly recommended.

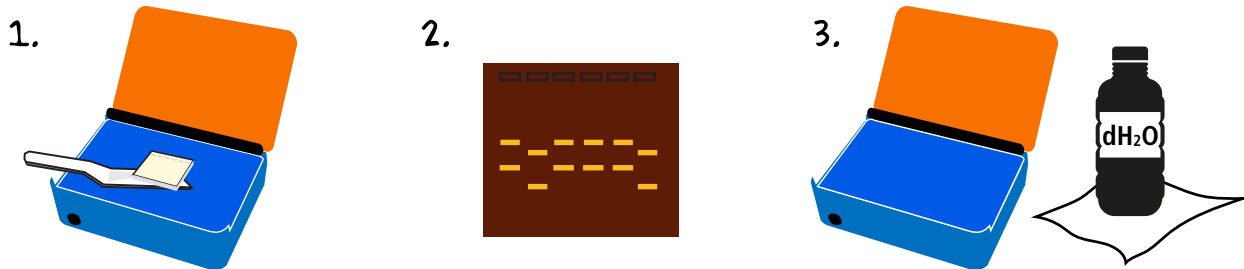

1. **SLIDE** gel off the casting tray onto the viewing surface of the transilluminator.
2. Turn the unit **ON**. DNA should appear as bright green bands on a dark background. **PHOTOGRAPH** results.
3. Turn the unit **OFF**. **REMOVE** and **DISPOSE** of the gel. **CLEAN** the transilluminator surfaces with distilled water.

